



www.uic.com
email: universal@uic.com

AMERICAS
Tel. 1-800-432-2607 or
Tel. +1-607-779-7522

CHINA, SHENZHEN
Tel. +86-755-2685-9108

CHINA, SHANGHAI
Tel. +86-21-6495-2100

EUROPE
Tel. +36-23-445-500

©2010 Universal Instruments
Corporation. All rights reserved.
All specifications are subject to change.

MC-5741 03/10



GENESIS_{SC}



semiconductor performance
at surface mount speeds

tailoring **System-level Solutions** for component assembly

Traditional methods of advanced assembly can no longer meet today's increasing production demands. Universal Instruments' Advanced Semiconductor solutions leverage Universal's legacy as a pioneer of leading-edge placement platforms, with high-accuracy enhancements that extend equipment capabilities into next-generation assembly. State-of-the-art handling, positioning, vision, and placement technologies allow you to perform challenging flip chip processes, process bare dies, and assemble complex optoelectronic components.

This powerful combination of advanced semiconductor capacity on Universal platforms provides a uniquely flexible equipment set that delivers maximum throughput per floor-space while offering a large reduction in operations and capital costs.

Universal's GenesisSC (Semiconductor) Platform has the inherent capability to assemble a complete module on a single machine, placing dies and passives precisely and seamlessly. This allows you to move quickly and cost-effectively into new technologies, exploiting modular handling solutions and common machine interfaces for heads, cameras, and feeders. This means our customers get to the market faster, optimize operating costs and enjoy long-term asset protection.

Universal Instruments' solutions include not only best-in-class equipment, but also proven in-depth process knowledge, application expertise and integration experience to ensure your equipment delivers your product at the highest possible yield and reliability, and at the lowest possible cost.

“My flexible Universal solution enables me to deal with converging technologies head-on, affording me greater productivity at a lower cost.”

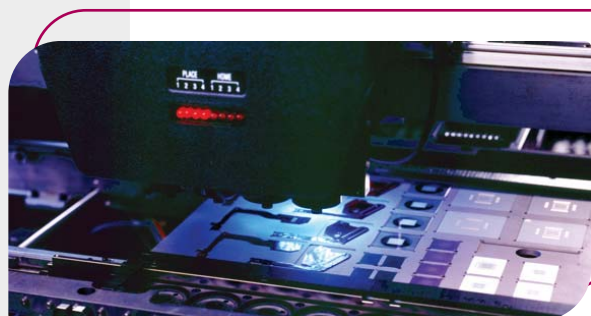
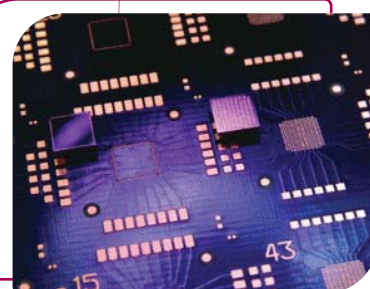

Capability

The Genesis Platform semiconductor configurations provide optimum capability for flip chip in package, or on board or flex; System-in-Package (SiP); Package-on-Package (PoP); Package-in-Package (PiP); and power devices (PQFN). Universal solutions also offer state-of-the-art wafer mapping capabilities, and place the widest component range from passives to SM devices.

- Advanced motor, motion control, and position encoder technologies
- Low-force placement capability
- Optimized lighting and optics
- Die delivery methods
- Gang processing for high speed
- Custom applications
- Linear Thin Film Applicator (LTFA) for flux and paste dipping

Reliability

Designed for a 24/7 manufacturing environment and backed by 24/7 support, Universal's placement platforms are highly mature. Universal has over 5,000 platforms in the field with an intrinsic machine availability of 98% or greater. And, more than 1000 of those are driven by VRM linear motor technology that maintains accuracy over time.

The core positioning system technology is complemented by mature process peripherals, including the LTFA, substrate handling, and flip chip vision.

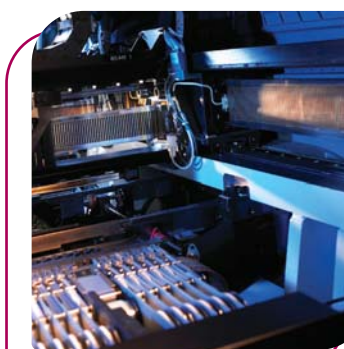

Accuracy

Universal's patented VRM[®] linear motor technology with 1-micron encoder resolution, a high-stiffness frame design, and specialized software allow for repeatability of ± 3 microns and accuracy of ± 10 microns.

Flexibility

Bare die and flip chip applications are supported with advanced options like megapixel camera technology, low-force placement, dip fluxing and look-before-pick imaging. Die delivery alternatives include wafer packs, gel packs and/or wafers up to 300mm.



Productivity

With on-the-fly imaging, high-speed operation, multi-spindle heads, automatic wafer feeding, and the applications and process expertise of our Advanced Process Laboratory, Universal platforms deliver unsurpassed throughput for high-volume flip chip applications.

Universal Semi solutions bring it all together

Free up your own engineering resources to focus on your core business while we leverage our expertise to your benefit. The result: a significantly shorter time to market, better-quality products and lower overall costs. Our well-established Advanced Technology Consortia members will attest to our long-standing experience in designing, implementing, enhancing, and optimizing the most complex component, board and final-assembly processes. With all levels of assembly converging into one, our knowledge and experience in semiconductor, circuit board, and final assembly all come together to support your transition to next-generation assembly.

Our advanced technology application expertise is unparalleled in the industry. We have been providing multi-chip assembly solutions to our customers since the early nineties. Printing, dispensing, chip mounting, die placement, flux dipping, pin transfer, die ejection, WL-CSP; just a few examples of proven, ready-to-ramp processes that we provide. Count on Universal to implement total process integration including third-party equipment along with our flexible placement platforms. We'll be sure and achieve the highest level of performance for your assembly process.

the **ideal solution** for **any market**

System-in-Package (SiP)

- Applications include: cell phone modules, small components and dies, medical, military
- Capability to mount multiple feeders including those for dies and passives
- On-board flux/solder paste dipping
- Lead frame handling
- Large area for handling wafer scale packaging
- Specialized semiconductor software provides interface to Innova direct die feeder
- Setup, calibrate, and verify for precision placement of critical components

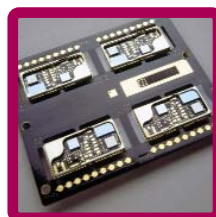

Universal Instruments' Advanced Process Laboratory plays a leading role in the greater electronics community, organizing research consortia, and building partnerships with academic and industry experts to identify and develop new and emerging technologies. This expertise and applications knowledge helps manufacturers improve yield, achieve continuous process improvements, and optimize product reliability and lifecycle for cutting-edge technologies.

Flip Chip in Package

- Applications include: MPU, DRAM, Flash
- Over 15 years experience in flip chip placement technology
- Extensive flip chip process knowledge acquired through both our acclaimed SMT Laboratory and field experience
- Optimum solutions for new flip chip applications and improvements to current processes
- Genesis Platform is fully configurable with cameras, tooling and nozzles to meet the exacting demands of all flip chip and SM products
- Innova direct die feeder delivers unbeatable flip chip productivity with a small footprint, on-line or off-line wafer expansion options, wafer map input or ink dot identification, and a capacity of up to 13 wafers
- Scalable solutions meet today's challenges – and those down the road
- Specialized semiconductor software provides for extremely high accuracy
- Setup, calibrate, and verify for precision across a broad area

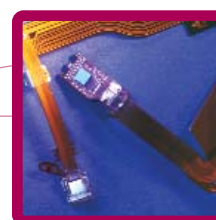

Flip Chip on Board/Flex

- Applications include: handheld, disk drive, medical
- Packages, chips, bare dies and passives on same machine
- High throughput for cost-sensitive applications
- Large area for handling wafer scale packaging
- Accuracy across the entire board
- Resolve patterns on flex circuitry for alignment purposes
- Specialized semiconductor software provides for fiducial and pattern recognition
- Setup, calibrate, and verify for precision across a broad area

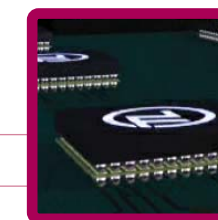

Package-on-Package (PoP) / Package-in-Package (PiP)

- Applications include: memory on MPU, memory on memory, smart power supplies
- Ability to place one device on another
- On-board flux/solder paste dipping
- Specialized semiconductor software for precision placement of components in same location
- Setup, calibrate, and verify for precision placement of fine pitch and CSPs

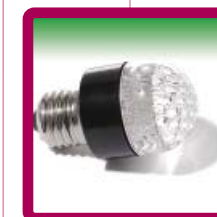

Power Devices - PQFN

- Applications include: hybrid for DC-DC and LED control (buck converters), hot swap control
- On-board flux/solder paste dipping
- Multi-die feeders for smart power devices
- Odd form handling for frame and clip applications
- Specialized semiconductor software provides for multiple processes on the same platform
- Setup, calibrate, and verify for precision low-force placement

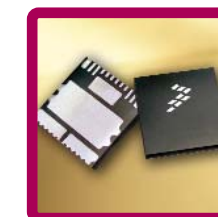

GenesisSC GI-14D

D-Series (dual-beam) GenesisSC

High-volume configuration delivering best-in-class throughput and accuracy for semiconductor applications. Maintains superior flexibility over dedicated solutions for technology changes.

- Dual-beam, dual-drive overhead gantry system
- Patented VRM[®] linear motor positioning system
- Two 7-spindle InLine7 placement heads
- Two upward-looking cameras
- Spec speed: 0.13 sec (26,900 cph)
- High Accuracy Option: +/- 10µm
- Component capabilities include flip chip, bare die, surface mount (0201 - 55mm square SFoV)
- Components down to 75µm thick
- Thin/thick, small/large substrate handling
- Feeder inputs: 120 dual-lane 8mm tape (2 ULCs)
- Feeder types: wafer, tray, tape, waffle and gel pak, and specials

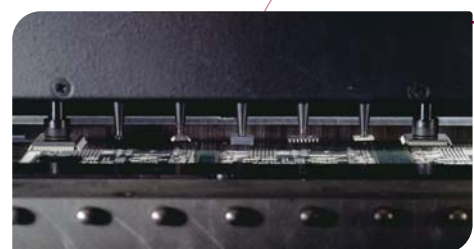
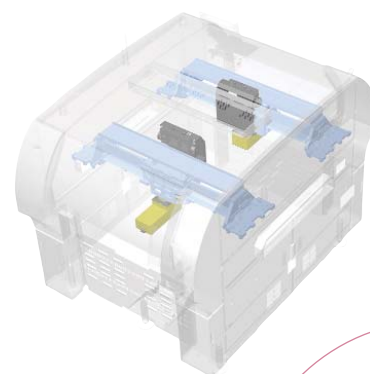

- Variable Reluctance Motor (VRM)**
- Patented technology at the core of all Universal platforms
 - Combines powerful acceleration, unmatched precision and simplified design for robust operation
 - High-accuracy (1µm resolution), closed-loop positioning control supports current, converging and emerging technologies
 - High acceleration – up to 2.5G
 - Dual-drive architecture reduces settle times
 - Thermally stable, non-magnetic
 - 15-year lineage – thousands of Universal VRM platforms in the field today
 - Direct drive technology stands the test of time to maintain its accuracy indefinitely



- Magellan Digital Camera**
- Large, 60mm field-of-view (FOV) minimizes multiple scans
 - High resolution of 1024 x 1024 for small parts
 - Front, side, and on-axis lighting that can be used individually or in combination
 - Bump size down to 50µm; options down to 25µm
 - On-the-fly centering of complex components at full speed

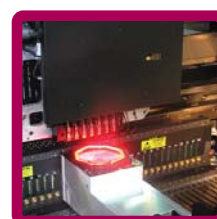

- InLine7 Placement Head**
- Provides high-speed IC and chip placement capability
 - Gang pick up to 7 components
 - Picks from trays, tape, tube and odd-form feeders

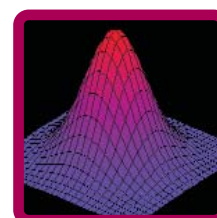

- Optimization of Accuracy and Speed**
- Closed-loop positioning
 - One-micron linear encoder resolution
 - Self-correcting dual-drive control

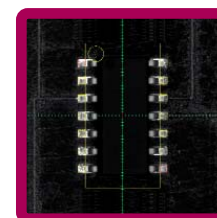

- NPI Software**
- Scrap-free first article build
 - Provides the ability to verify the complete production process: board, feeders, fiducials, components, pre-placement x, y and theta data, and post-placement data

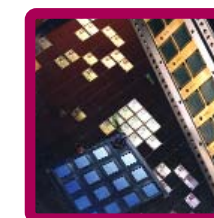

- Presentation of all Packaging Formats, Including Wafer Feeding**
- Enables flexible, cost-effective performance
 - Simplifies assembly requirements
 - Sustains product life

GI-14D SPECIFICATIONS		
Spec Placement Rate	Max	26,900 cph / 0.13 sec per component
	4-Board IPC Chip (1608)	18,700 cph / 0.19 sec per component
	4-Board IPC IC (100 QFP)	7,400 cph / 0.49 sec per component
Accuracy		±40µm @ 1.33 Cpk / ±30µm @ 1.00 Cpk
	High-Accuracy Option	±10µm @ Cpk > 1.0
PCB Dimensions	Maximum Size (WxLxH)	508 x 508 x 5.08mm (20 x 20 x 0.2")
	Minimum Size (WxLxH)	50.8 x 50.8 x 0.508mm (2 x 2 x 0.02")
	Maximum Weight	2.72kg (6 lbs)
	Topside Clearance	26.5mm (1.04")
	with big board kit	Maximum Size (WxLxH)
Component Range	Maximum Weight	6.8kg (15 lbs)
	Maximum Size (WxLxH)	55 x 55 x 25mm ¹ (2.17 x 2.17 x 0.98")
	Minimum Size (WxLxH)	0.25 x 0.5 x 0.15mm (0.01 x 0.02 x 0.006")
Machine Dimensions	Maximum Weight	27g (up to 130g via RFQ)
	(LxDxH)	1676 x 2248 x 1930mm (66 x 88.5 x 75.9")
Machine Weight		3500kg (7700lbs)

¹ Consult the General Specification for component capability specifics

Linear Thin Film Applicator (LTFA)

On-board dipping for maximum efficiency

The Linear Thin Film Applicator (LTFA) creates a thin film of flux, solder paste, or adhesive. Flip chips, Stacked CSPs and other area array packages are individually or gang dipped, thereby applying the necessary amount of material to the appropriate area.



- Linear actuation for speed and repeatability
- Gang dipping of all 4/7 spindles
- Interchangeable fixed-depth flux channels (no adjustments) for accurate film thickness control
- Programmable milling cycles
- Programmable dipping dwell time
- Programmable Maintenance Monitor
- Easy changeover
- Quick release tooling for easy cleaning
- Large reservoir (up to 8 hours run time)
- Supports both flux and solder paste dipping



GenesisSC GX-11S

S-Series (single-beam) GenesisSC

Most flexible configuration delivering best-in-class throughput and accuracy for semiconductor applications. Offers widest component range without reconfiguration.

- Single-beam, dual-drive overhead gantry system
- Patented VRM[®] linear motor positioning system
- Mixed-head / dual-head configuration
- One/two upward-looking cameras with three magnification options
- Spec Speed: 0.24 sec (15,300 cph)
- High Accuracy Option: +/-10µm
- Component capabilities include flip chip, bare die, surface mount (0201 - 55mm square SFoV)
- Components down to 75µm thick
- Thin/thick, small/large substrate handling
- Feeder inputs: 120 dual-lane 8mm tape (2 ULCs)
- Feeder types: wafer, tray, tape, waffle and gel pak, and specials

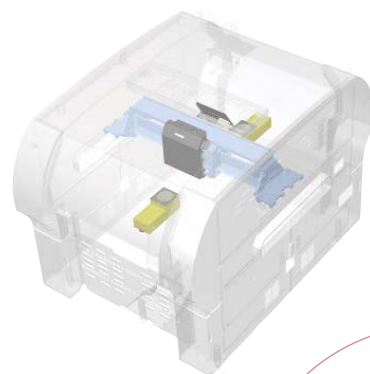

- Gang Flux Dipping for Efficiency**
- Linear Thin Film Applicator (LTFA) enables gang dipping on both the InLine7 and InLine4 heads to maximize throughput
 - Dual fluxer support allows for the use of two fluxers on single- and dual beam Genesis SC Platforms

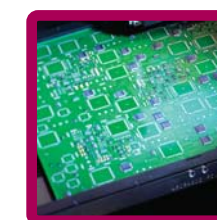

- Large Board Size Capability**
- Up to W508mm x L508mm (20" x 20") capability to address any market or end product application
 - Board support for maximum yield under all circumstances

GX-11S SPECIFICATIONS

Spec Placement Rate	Max	15,300 cph / 0.24 sec per component
	4-Board IPC IC (100 QFP)	2,500 cph / 1.4 sec per component
Accuracy		±40µm @ 1.33 Cpk / ±30µm @ 1.00 Cpk
	High-Accuracy Option	±10µm @ Cp > 1.0
PCB Dimensions	Maximum Size (WxLxH)	508 x 508 x 5.08mm (20 x 20 x 0.2")
	Minimum Size (WxLxH)	50.8 x 50.8 x 0.508mm (2 x 2 x 0.02")
	Maximum Weight	2.72kg (6lbs)
	Topside Clearance	26.5mm (1.04")
with big board kit Component Range	Maximum Size (WxLxH)	610 x 813 x 5.08mm (24 x 32 x 0.2")
	Maximum Size (WxLxH)	55 x 55 x 25mm ¹ (2.17 x 2.17 x 0.98")
	Minimum Size (WxLxH)	0.25 x 0.5 x 0.15mm (0.01 x 0.02 x 0.006")
	Maximum Weight	35g (up to 130g via RFQ)
Machine Dimensions Machine Weight	(LxDxH)	1676 x 2248 x 1930mm (66 x 88.5 x 75.9")
		3250kg (7150lbs)

¹ Consult the General Specification for component capability specifics

The two placement heads on the GenesisSC GX-11S Platform offer a wide overlapping component range so that you can seamlessly optimize your application, regardless of component mix. Fast setup and changeover in higher mix environments maximizes productivity.

InLine 4 Head (5kg insertion)

InLine 7 Head (150mm)

- Chip
- MELF
- Tant Cap
- SOIC
- TSOP
- DPAK
- QFP
- BGA
- PLCC
- CSP
- Electrolytic Cap
- Connectors
- CCGA
- Odd Form
- Pin-in-Paste
- Flip Chip

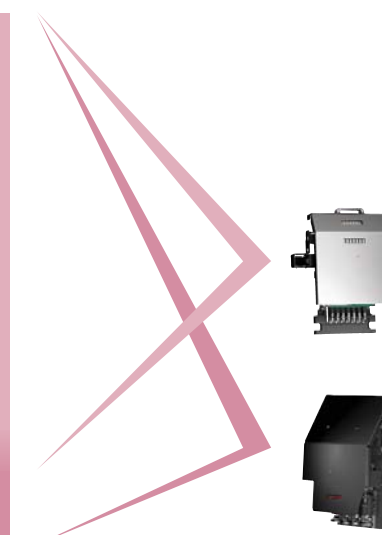

InLine7 Head - The all-around performer

The InLine7 Head quickly and accurately places components as small as 0201 up to 55mm square and 25mm tall with single field-of-view inspection. Gang pick up to seven components.

InLine4 Head - Unmatched flexibility and odd-form capability

To handle your extreme application requirements, the InLine4 Head supports special processes such as pin-in-paste and flip chip. For components requiring force fit, the InLine4 HF (High Force) head offers programmable insertion forces from 150 to 5000 grams. The InLine4 HP (High Precision) head delivers extreme accuracy for precision applications. Additional InLine4 features include selectable placement delay and normal, medium and slow tact modes.

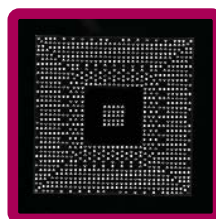

Advanced Vision System

- Multiple inspection algorithms enable efficient placement of components with minimum programming time
- Choose from a group of leaded, non-leaded, or BGA inspection algorithms, or create your own with our custom pattern inspection that is useful for connectors and odd-form



High-Volume SM/Odd Form Placer

- Extends the GSM Odd Form Legacy
- A large available selection of custom nozzles, feeders, and tracks
- Addresses odd form snap-in components with up to 5kg programmable insertion force
- Add a large-bore nozzle changer and on-the-fly nozzle change capability and you have the industry's premier SM/odd form placement machine

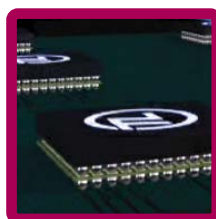

Easily Configured for PoP

- Specialized options allow you to address this next-generation assembly challenge at competitive speeds
- Take advantage of four- or seven-component single flux and paste dip functionality superior to the single-dip capability of competitive offerings



Complementary Placement Heads

- A wide overlap in component range between placement heads delivers superior utilization and line balancing
- Fast setup and changeover without reconfiguration or limitation, reducing investment costs and maximizing productivity

Innova Direct Die Feeder

Delivering high-speed Bare Die to the mainstream

Embrace the convergence era of electronics assembly with the Innova and Innova + Direct Die Feeders. This revolutionary technology enables the presentation of wafer-level devices to Universal's Genesis Platform without incurring costly packaging charges.

- Eliminates upstream wafer sorting
- Provides a broad range of die delivery options
- Allows the installation of multiple feeders on a single placement machine
- True flexibility enables relocation as demands change
- On-board machine vision qualifies ink dots, bumps, corners or other features; only selected devices are delivered to placement
- Presents a wide variety of flip chips or circuit-up devices with simple changeovers
- State-of-the-art vision processing
- Optimal solution of high reliability, high speed and flexibility
- Processes wafers of various sizes, up to 300mm¹
- Up to 13 wafers (on Innova +)
- Wafer map input or ink dot identification
- Bar code identification and tracking of wafers
- Parallel processing provides optimum throughput
- Optimizes the use of clean room space by

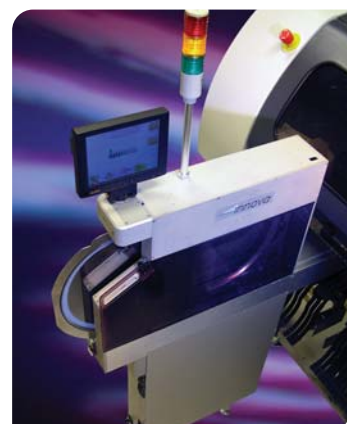

Portable High-Speed Bare Die

- Easy-to-use operator interface
- Windows-based control that quickly connects to keyboard, touch-screen monitor, and mouse for programming and troubleshooting

Eliminate Packaging Costs

- The introduction of integrated active and passive devices at the wafer level is now a reality
- Eliminate the cost associated with packaging trays and embossed tapes with a new form of component delivery

Minimum Feeder Slot Consumption

- Deliver thousands of die per hour to your placement machine, while consuming only 3-4 feeder slots
- Innova and Innova + are only 80mm wide

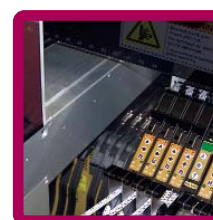

High-Volume Bare Die or Mixed Assembly

- In combination with modern-day, high-volume flexible placement systems, Innova enables delivery of thousands of die per hour
- Applications include: Bluetooth and WiFi, Automotive Hybrids, Security and a host of other applications
- Streamline your process for improved efficiency

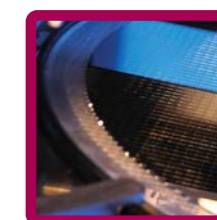

Ability to Pick from Multiple Wafer Sizes

- Processes wafers up to 300mm
- Available adaptors for the Innova feeder accommodate various frame sizes and rings

INNOVA FEEDER SPECIFICATIONS		
Throughput Rate ¹	Flip Chip	4,700 max uph (unit per hour) for 1mm die
	Direct Chip	4,000 uph (unit per hour) for 1mm die
Presentation Accuracy	Verified against 1.0mm die size:	X,Y = ± 0.15mm @ 3s / ±27.0° (Cpk ~1)
	Pick Point Range	Standard Pick Height: 139.8mm (5.51") Feeder-to-Feeder Spacing: 130mm (5.19") - Feeder Nominal = 127.0mm (5.0") - 3mm (.19") minimum total clearance for side by side systems (Innova only)
Wafer Specification	Present Position Repeatability	±150µm (±6 mils)
	Maximum Size	300mm (12")
	Minimum Size	100mm (4") ²
Vision Recognition	Expansion Depth	6.35mm, 6.0mm, 0.0mm (unexpanded) ³
	Recognition Methods	Thresholding, Pattern Matching, Corner Detection, Solder Bump Detection, Wafer Mapping
Die Specification	Minimum Size (L x W)	0.7mm x 0.7mm (0.027" x 0.027")
	Maximum Size (L x W)	11.0mm x 11.0mm (0.43" x 0.43")
	Minimum Thickness	75 µm (0.003")
Nesting	Maximum Thickness	4.0mm (0.163" nominal)
	Die Material	Silicon, Gallium Arsenide, Ceramic, Glass
Cycle Times	Ball Types	Ball bumps, Stud bumps
	Capability	Fully functional shuttle with a maximum nesting capability up to 7
Machine Dimensions	Extract to Present	Time required for a single die to be extracted from the wafer and presented at the pick point: <2.5 seconds
	Power Up	Time required boot-up, i.e. time from pushing the power-up button until the Innova completes initialize sequence and allows user to access: <2.0 minutes
	Initialization Cycle	Time required for Innova to re-home all motors in the system and reset the encoders: < 2.0 minutes
Machine Weight	Wafer Changeover	Fully Manual Change: The user unloads a wafer using the UNLOAD function, replaces the wafer by hand, and uses the LOAD function to reinsert that (or another) wafer. This process is not time specified. Auto Load/Unload: < 100.0 seconds
	(LxDxH)	1315.7 x 126.9 x 1568.9mm (51.8 x 5.0 x 54.5")
		45kg (99lbs) / Innova Plus 85kg (143lbs)

¹ Does not include wafer changeover

² Requires larger wafer frame

³ Dependant on wafer/tape type

¹ Application on the Innova Plus may vary. Consult your Sales Engineer for details.